

Simple Modal Filter Based on Microstrip Line

Indira Y. Sagiyeva^{ORCID}, Talgat R. Gazizov^{ORCID}

Tomsk State University of Control Systems and Radioelectronics, Tomsk, Russian Federation

Cite this article as: I. Y. Sagiyeva and T. R. Gazizov, "Simple modal filter based on microstrip line," *Electrica*, 23(3), 516-521, 2023.

ABSTRACT

The article presents the results of a study of a modal filter (MF) based on a microstrip line (MSL) with two side conductors grounded at both ends. For the first time, the quasi-static simulation and measurements of the filter are conducted with two devices, and the results are compared. Frequency dependences of $|S_{11}|$ and $|S_{21}|$ are measured and calculated in the range from 0 to 10 GHz. At the MF output, the time response to an ultrashort pulse (USP) was analyzed. It was experimentally proved that the performed quasi-static simulation was correct. The simulation and measurement results showed remarkable consistency. The proposed MF provides the protection of electrical circuits from USP by decomposing it into two pulses with the amplitudes that are more than three times smaller. This confirms that such MF obtained simply by adding to a MSL two passive conductors grounded at both ends can be used to create simple and cheap protection, for example, of critical radioelectronics against powerful intentional USP created by electromagnetic weapons.

Index Terms—Modal filter, microstrip line, protective device, time response, ultrashort pulse

I. INTRODUCTION

The widespread introduction of radioelectronic equipment (REE) in all areas of life leads to an aggravation of the problem of ensuring electromagnetic compatibility. The problem is caused by an increase in the power of devices, the cutoff frequency of useful signals, and the package density of printed circuit boards. All these factors lead to an increase in the REE susceptibility to electromagnetic influences of various nature. In addition to interference generated by useful signals, it is necessary to pay attention to intentional electromagnetic interference, especially ultrashort pulses (USPs) [1–3]. Their influence can lead to various consequences, from deterioration in functioning to a complete failure of the system [4]. Therefore, an important task is to improve the interference protection of the REE. To do this, it is important to create new protective devices.

One such device is a modal filter (MF) based on the use of coupled transmission lines with modal decomposition [5]. In fact, there are various MFs based on microstrip lines (MSLs) [6–16] where the minimum and equal pulse voltages at the output have been obtained. In these MFs, the resistances at the ends of the passive conductor are equal to the geometric mean of the wave impedances of the modes or reduced to a short circuit at one end and open circuit on the other. Meanwhile, MFs in which equal pulse voltages are obtained when the passive conductor is short-circuited at both ends are important, since the manufacture of such MFs is easier and cheaper. Moreover, such MFs have a structure (in the geometric model of cross-section) with considerably asymmetric placement of active and passive conductors relative to a reference conductor. For example, the authors from [17] proposed an MF based on MSL with conductors placed on top and grounded at both ends. However, placing the two conductors on the top makes the MF more complicated and expensive. Meanwhile, for simpler fabrication, they are better placed on the sides of the MSL signal conductor, although this may slightly degrade the MF characteristics (Fig. 1). Therefore, it is relevant to investigate such an MF. Making its prototype requires the designing, which includes the following steps: building a geometric model of the cross-section with the search for optimal parameters of the line [width (w) and thickness (t) of conductors, the distance between them (s), the thickness of the substrate (h), and its relative permittivity (ϵ_r)]; building a schematic circuit with setting boundary conditions at the ends of conductors, line length, and input excitation; simulation of a response to a given excitation; and creating a photomask for a printed circuit board (PCB), making a real prototype. The purpose of the work is to present the results of such work.

Corresponding author:

Indira Y. Sagiyeva

E-mail:

indira_sagiyeva@mail.ru

Received: May 20, 2022

Accepted: March 8, 2023

Publication Date: July 18, 2023

DOI: 10.5152/electrica.2023.22088



Content of this journal is licensed under a Creative Commons Attribution-NonCommercial 4.0 International License.

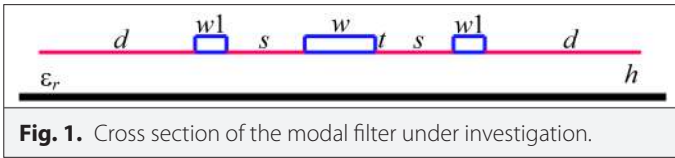

Fig. 1. Cross section of the modal filter under investigation.

II. BACKGROUND OF THE STUDY

Any MF can be simulated using electrodynamic and quasi-static approaches. Electrodynamic numerical methods, being universal, allow solving problems with rather complex geometry. However, the requirements for computer speed and memory may be excessively high, and, therefore, the task solution will be impossible. Quasi-static methods are much more efficient in calculations, provide acceptable accuracy, allow a physical understanding of the problem, and make it possible to determine per-unit-length parameters and response to a given impact. In the quasi-static approximation, the analysis of N-conductor structures is based on the calculation of square matrices (of order N) of the per-unit-length electrostatic (\mathbf{C}) and electromagnetic (\mathbf{L}) induction coefficients by the numerical method of moments, which is presented in detail in [18]. If losses are supposed to be taken into account, two more matrices are used: conductivity (\mathbf{G}) and resistance (\mathbf{R}) [19]. These matrices are then used in solving the Heaviside telegraph equations to analyze signal integrity as well as to obtain time response and other parameters [20]. Therefore, to analyze the considered structure, it is relevant to use quasi-static models instead of electrodynamic ones.

For the MF under study, we used quasi-static simulation in the TALGAT system [21] and prototype measurements with two devices. The cross-section of the MF has the following parameters: $t = 70 \mu\text{m}$,

$w = 0.45 \text{ mm}$, $w_1 = 0.2 \text{ mm}$, $h = 0.5 \text{ mm}$, $d = 1 \text{ mm}$, $s = 0.45 \text{ mm}$, $\epsilon_r = 4$, and $\text{tg}\delta = 0.03$, as shown in Fig. 1. Values of parameters h , t , ϵ_r , and $\text{tg}\delta$ were taken according to low-cost foiled fiberglass material from which the MF prototype was made. The value of the parameter d takes into account the length of dielectric boundary. Parameters s , w , and w_1 were optimized by a heuristic search to decompose the exciting pulse into two pulses at the MF output and align their voltage magnitudes.

Fig. 2 shows MF photomasks of the top and bottom layers for making a prototype with dimensions of $100 \times 100 \text{ mm}^2$. To reduce the length, the MF is bent into a meander with a distance between half-turns of 10 mm .

The simulation used the circuit diagram shown in Fig. 3A. There, the signal conductor is connected to a source of pulsed signals represented in the diagram by an ideal source of electromotive force (EMF) E and internal resistance R_1 . At the other end, the conductor is connected to the load R_2 . Circuit parameters are as follows: the line length (l) is 337 mm and the resistances ($R_1 = R_2$) are 50 Ohm (the example of the MF for operation in a standard 50-ohm path is considered). The source of input excitation for simulation and measurements is a waveform of trapezoidal pulse with an EMF amplitude of 1 V and rise, flat top, and fall times of 40 ps (Fig. 3B). This form is often used to simulate useful digital signals as well as interfering USP. Moreover, its combinations can represent other influences.

The measurements of S parameters were performed using vector network analyzers (VNAs) ZVA 40 and P4226 (Fig. 4) connected to the prototype via SMA-50-0-1/111_NE connectors (upper bound frequency 18 GHz) and measuring cables. Before the start of measurements, a two-port calibration was performed.

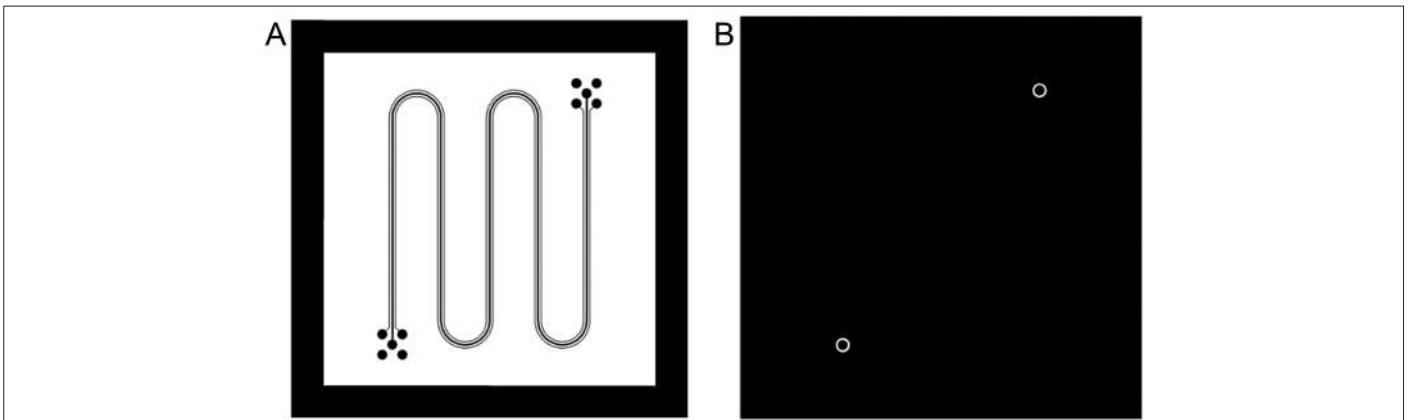

Fig. 2. (A) Top and (B) bottom layers of the modal filter photomask.

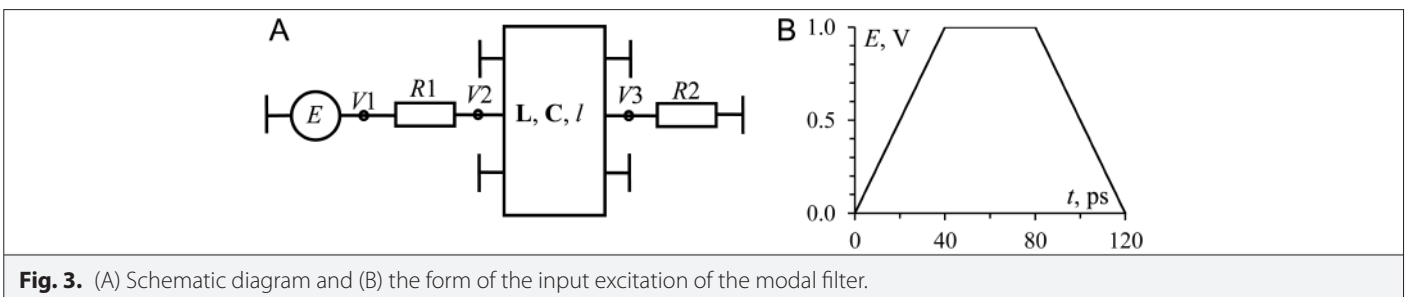

Fig. 3. (A) Schematic diagram and (B) the form of the input excitation of the modal filter.

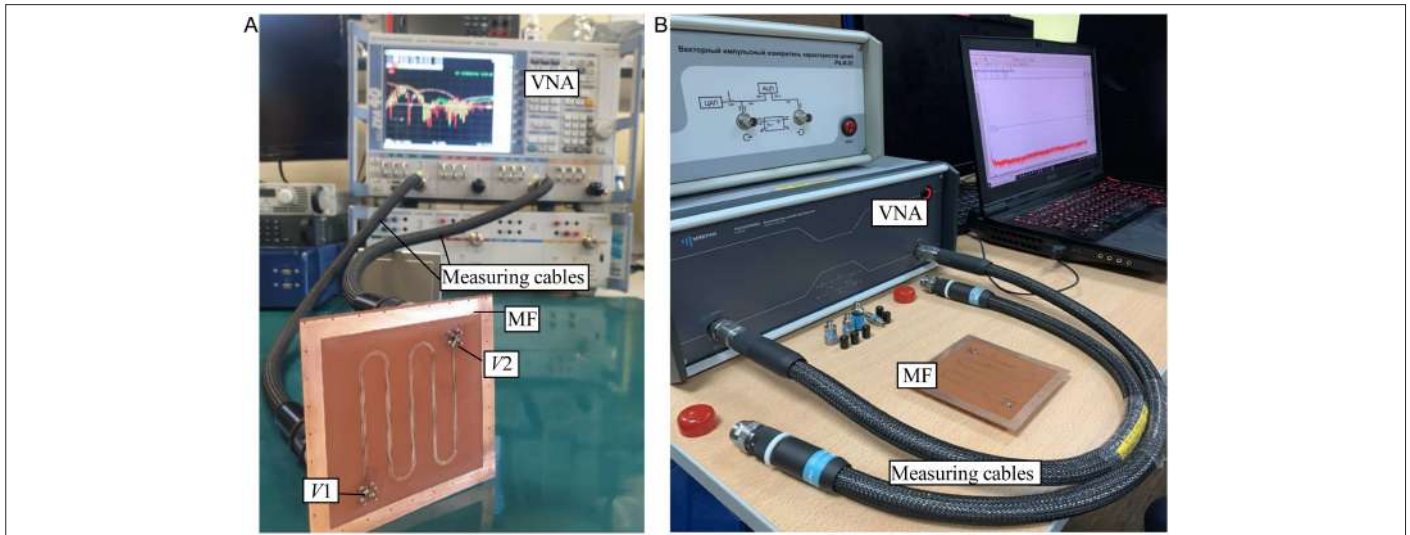

Fig. 4. (A) ZVA 40 and (B) P4226 for measuring the frequency response of the modal filter (MF). VNA, vector network analyzer.

The MF was analyzed in the frequency range from 0 to 10 GHz. At the same time, fiberglass FR-4 was specified as the substrate material and copper as the material for the conductor. Then, the S-parameters were measured, and the time responses to the USP excitation were obtained in the advanced design system (ADS) (Fig. 5).

III. RESULTS

The set of cross-sectional parameters from Fig. 1 defines the **L** and **C** matrices, calculated in the TALGAT system:

$$\mathbf{L} = \begin{bmatrix} 461.18 & 68.50 & 22.71 \\ 68.50 & 345.43 & 68.50 \\ 22.71 & 68.50 & 461.18 \end{bmatrix} \text{ nH/m,}$$

$$\mathbf{!} = \begin{bmatrix} 63.33 & -6.27 & -0.41 \\ -6.27 & 91.68 & -6.27 \\ -0.41 & -6.27 & 63.33 \end{bmatrix} \text{ pF/m.}$$

The square root of eigenvalues for product of matrices **L** and **C** determines the values of the per-unit-length delays of the modes propagating in the lines: $\tau_1 = 5.140$ ns/m, $\tau_2 = 5.287$ ns/m, and $\tau_3 = 5.830$ ns/m.

Fig. 6 represents the frequency dependences of $|S_{11}|$ and $|S_{21}|$ obtained from quasi-static simulation and measurements. It can be seen that the MF under study is a low-pass filter. The frequencies of $|S_{21}|$ minima in Fig. 6B are approximately defined by the difference of the per-unit-length delays and the line length as $f_k = k/[2(\tau_3 - \tau_1)]$, where $k = 1, 3, 5 \dots$. For example, for $k = 1, 3$, we get $f_1 = 2.15$ GHz and $f_2 = 6.45$ GHz, which are close to the values of the minima in Fig. 6B.

(multiple minima are caused by multiple reflections of three modes propagating in the structure). The bandwidth (at the level of -3 dB) was 0.521 GHz for quasi-static simulation, 0.505 GHz for P4226, and 0.505 GHz for ZVA 40. The results are in good agreement with each other. The maximum deviations of the simulation and measurement results are observed at frequencies of 7.38 GHz for $|S_{11}|$ and 6.39 GHz for $|S_{21}|$. The differences can be explained by the fact that the

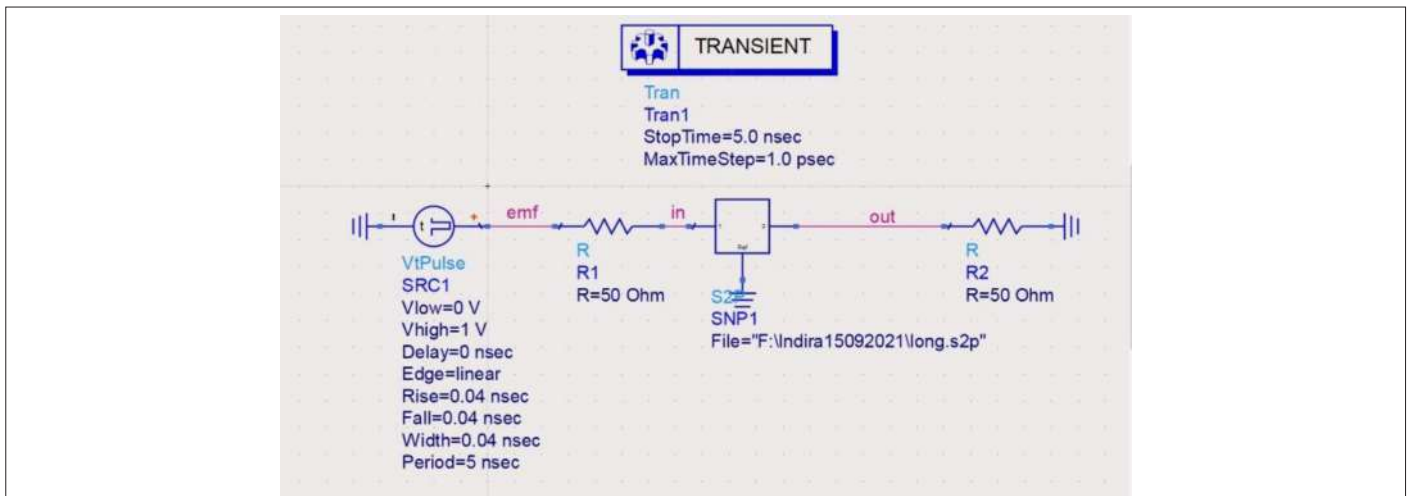

Fig. 5. Equivalent circuit for obtaining a time response in the advanced design system.

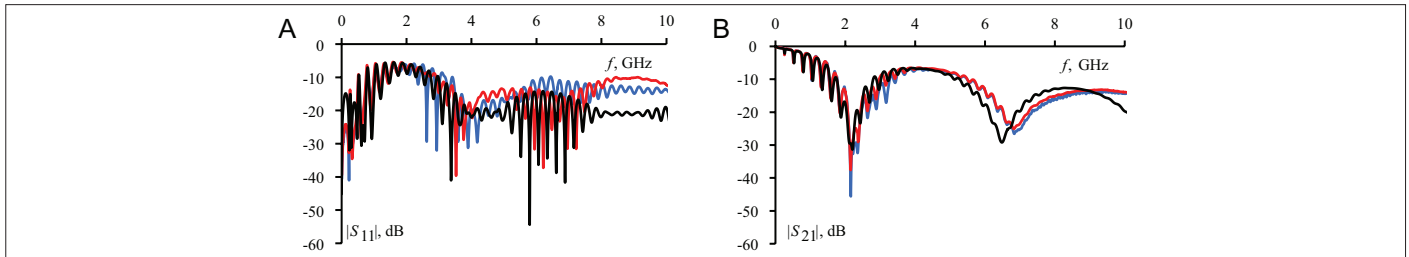

Fig. 6. (A) Frequency dependences of $|S_{11}|$ and (B) $|S_{21}|$ for the modal filter prototype obtained during simulation (—) and measurements with vector network analyzers P4226 (---) and ZVA 40 (---).

frequency dependence of the permittivity and the influence of SMA connectors, as well as the measurement error, were not taken into account in the simulation.

Fig. 7 represents output voltage waveforms obtained from the quasi-static simulations in TALGAT and from measured frequency responses in the ADS. It can be seen that the USP is divided into two pulses with the amplitudes that are more than three times smaller (relative to a half of EMF amplitude). Due to the symmetry of the two side conductors, the pulse amplitude in the mode 2 is zero, and only pulses of modes 1 and 3 are left. In this case, the results are in fairly good agreement.

Table I shows the delays of pulse 1 and the amplitudes of pulses 1 and 2. The results of ZVA 40 and quasi-static simulation are the best in terms of delays, with the deviations being 1.5%. In P4226 measurements, the pulse amplitudes are aligned. The relative deviations of the measurement and simulation results in terms of amplitudes

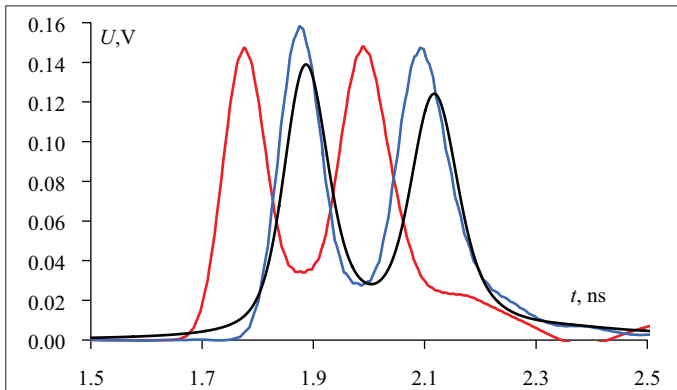

Fig. 7. Voltage waveforms at the output of the MF prototype, obtained by simulation (—) and measurements with vector network analyzers P4226 (---) and ZVA 40 (---).

TABLE I. THE PULSE AMPLITUDES (U_1 , U_2) AND DELAY (t_1) AT THE MF OUTPUT

Parameter	t_1 (ns)	U_1 (V)	U_2 (V)
Quasi-static	1.779	0.133	0.117
P4226	1.65	0.143	0.143
ZVA 40	1.754	0.154	0.143

MF, modal filter.

for pulse 1 are 7.5% for P4226 and 15% for ZVA 40, and for pulse 2 it is 22% for both devices. Such deviations may be caused by the factors mentioned above as well as loose consideration of delays in branches, connectors, and junctions.

IV. CONCLUSION

This paper presents the results of a comprehensive analysis of an MF based on an MSL with two side conductors grounded at both ends. The frequency responses showed that the investigated MF is a low-pass filter. At the same time, in the time domain, the USP was divided into two pulses with more than three times smaller amplitudes. The results of quasi-static simulation and measurements performed with two VNAs were shown to be in good agreement with each other, thus confirming the correctness of the calculations. This confirms that such MFs that simple in design and fabrication with passive conductors grounded at both ends can be used to create simple and cheap protection devices against USP. An example is the implementation of such protection in PCBs of critical radioelectronics against powerful intentional USP created by electromagnetic weapons.

Peer-review: Externally peer-reviewed.

Author Contributions: Concept – I.Y.S.; Design – T.R.G.; Supervision – T.R.G.; Materials – I.Y.S.; Data Collection and/or Processing – I.Y.S.; Analysis and/or Interpretation – T.R.G.; Literature Search – I.Y.S.; Writing Manuscript – I.Y.S.; Critical Review – T.R.G.

Declaration of Interests: The authors have no conflict of interest to declare.

Funding: The study was supported by the Ministry of Science and Higher Education of the Russian Federation, project FEWM-2022-0001.

REFERENCES

- W. A. Radasky, "The threat of intentional interference to wired and wireless systems," International Zurich Symposium on Electromagnetic Compatibility, Zurich, Switzerland, 2006, pp. 160–163.
- W. A. Radasky, C. E. Baum, and M. W. Wik, "Introduction to the special issue on high-power electromagnetics and intentional electromagnetic interference," *IEEE Trans. Electromagn. Compat.*, vol. 46, no. 3, pp. 314–321, 2004. [\[CrossRef\]](#)
- D. Mansson, R. Thottappillil, and M. Backstrom, "Methodology for classifying facilities with respect to intentional electromagnetic interference," *IEEE Trans. Electromagn. Compat.*, vol. 51, no. 1, pp. 46–52, 2009. [\[CrossRef\]](#)
- D. V. Giri, and F. M. Tesche, "Classification of intentional electromagnetic environments (IEME)," *IEEE Trans. Electromagn. Compat.*, vol. 46, no. 3, pp. 322–328, 2004. [\[CrossRef\]](#)
- A. O. Belousov, and T. R. Gazizov, "Systematic approach to optimization for protection against intentional ultrashort pulses based on multi-conductor modal filters," *Complexity*, vol. 2018, pp. 1–15, 2018. [\[CrossRef\]](#)

6. E. B. Chernikova, A. A. Kvasnikov, A. M. Zabolotsky, and S. P. Kuksenko, "Evaluating the influence of the magnetic permeability of the microstrip modal filter substrate on its frequency characteristics," *J. Phys. Conf. S.*, vol. 1611, no. 1 (2020), pp. 1–4, 2020. [\[CrossRef\]](#)
7. R. Khazhibekov, and A. Zabolotsky, "Modal filter with interdigital structure of conductors for 100 Mbit/s Ethernet equipment protection," International Siberian Conference on Control and Communications. Tomsk, Russia: SIBCON, April 18–20, 2019, pp. 1–4. [\[CrossRef\]](#)
8. A. O. Belousov et al., "From symmetry to asymmetry: The use of additional pulses to improve protection against ultrashort pulses based on modal filtration," *Symmetry*, vol. 12, no. 7, pp. 1–38, 2020. [\[CrossRef\]](#)
9. E. B. Chernikova, and A. A. Ivanov, "Using composite insulating materials to improve modal filter performance," 21st International Conference of Young Specialists on Micro/Nanotechnologies and Electron Devices EDM. Erlagol, Altai, June 29 –July 3, 2020, pp. 187–190. [\[CrossRef\]](#)
10. Y. S. Zhechev, A. H. Alhaj Hasan, and K. P. Malygin, "New technique for improving modal filter performance by using an electromagnetic absorber," *IEEE Access*, vol. 10, 86663–86670, 2022. [\[CrossRef\]](#)
11. M. A. Samoylichenko, and A. M. Zabolotsky, "Simulation the time response to ultra-short pulse excitation of two cascaded modal filters with a passive conductor in the reference plane," *J. Phys. Conf. S.*, vol. 1611, no. 1, pp. 1–4, 2020. [\[CrossRef\]](#)
12. Y. S. Zhechev, I. A. Ivantsov, and A. M. Zabolotsky, "Multicriteria optimization of a four-layer reflection-symmetric modal filter parameters for ESD protection," *J. Phys. Conf. S.*, vol. 1862, no. 012020, pp. 1–6, 2021.
13. V. O. Gordeyeva, A. O. Belousov, and N. O. Vlasova, "Optimization of a 3-conductor modal filter with a circular cross section by evolutionary strategies with limitations," 23rd International Conference of Young Specialists on Micro/Nanotechnologies and Electron. Devices EDM. Altai, June 30 –July 4, 2022, pp. 218–222. [\[CrossRef\]](#)
14. E. B. Chernikova, "Studying the structures of modal filter with circular reflection symmetry," *J. Phys. Conf. S.*, vol. 1862, no. 1, pp. 1–5, 2021. [\[CrossRef\]](#)
15. A. M. Lakoza, V. P. Kosteletsky, and M. E. Komnatnov, "Measuring radiated emission levels and EMI susceptibility of protection devices based on modal filtering," 23rd International Conference of Young Specialists on Micro/Nanotechnologies and Electron. Devices EDM. Altai, June 30 –July 4, 2022, pp. 214–217. [\[CrossRef\]](#)
16. E. B. Chernikova, and V. P. Kosteletskii, "Comparative analysis of an LC-filter and a reflection symmetric modal filter," 23rd International Conference of Young Specialists on Micro/Nanotechnologies and Electron. Devices EDM. Altai, June 30 –July 4, 2022, pp. 186–190. [\[CrossRef\]](#)
17. I. Y. Sagiyeva, Z. M. Kenzhegulova, T. R. Gazizov, and R. S. Surovtsev, "Modal filters based on a microstrip line with air conductors grounded at both ends," International Conference of Young Specialists in the Field of Electronic Devices and Materials, Altai, 2021, pp. 176–179.
18. T. R. Gazizov, "Analytic expressions for mom calculation of capacitance matrix of two dimensional system of conductors and dielectrics having arbitrary oriented boundaries," IEEE EMC International Symposium, Symposium Record. International Symposium on Electromagnetic Compatibility, 2001, pp. 151–155.
19. G. L. Matthaei, and G. C. Chinn, "Approximate calculation of the high-frequency resistance matrix for multiple coupled lines," IEEE MTT-S Microwave Symposium Digest, 1992, pp. 1353–1354. [\[CrossRef\]](#)
20. A. R. Djordjevic, T. K. Sarkar, and R. F. Harrington, "Time-domain response of multiconductor transmission lines," *Proc. IEEE*, vol. 75, no. 6, pp. 743–764, 1987. [\[CrossRef\]](#)
21. A. A. Kvasnikov, S. P. Kuksenko, and F. F. Idrisov, "Prototype of EMC Expert system for optimal design of radioelectronic equipment," *J. Phys. Conf. S.*, vol. 1862, no. 012020, pp. 1–6, 2021.



Indira Y. Sagiyeva was born in 1992. In 2014, she received a B.Sc. degree from the Almaty University of Energy and Communications, Almaty, Kazakhstan, and in 2016 an M.Sc. degree from the Tomsk State University of Control Systems and Radioelectronics (TUSUR), Tomsk, Russia. In 2020, after graduating from TUSUR, she qualified as a teacher-researcher. In 2021, she received a Ph.D. degree in Antennas, Microwave Devices, and their Technology. Currently, she works as a junior research fellow at TUSUR. She is the author and coauthor of 59 scientific papers.



Talgat R. Gazizov was born in Jalal-Abad, Kyrgyzstan, in 1963. He received the Ph.D. degree in Improvement of Circuit Board Interconnections and the D.Sc. degree in Reduction of Electric Signal Distortions in the Interconnections and Effects of Power Electromagnetic Interference from the Tomsk State University of Control Systems and Radioelectronics, Tomsk, Russia, in 1999, and 2010, respectively. He has authored/coauthored more than 482 scientific papers, including 11 books. His research interests include signal integrity problems.