

PAPER • OPEN ACCESS

## Multiphase power supply when inverting currents for group of Peltier elements

To cite this article: A V Osintsev *et al* 2018 *J. Phys.: Conf. Ser.* **1015** 052023

View the [article online](#) for updates and enhancements.

# Multiphase power supply when inverting currents for group of Peltier elements

A V Osintsev, A A Sobko, M E Komnatnov

Tomsk State University of Control Systems and Radioelectronics, 40, Lenina Ave., Tomsk, 634050, Russia

E-mail: [kubenet@gmail.com](mailto:kubenet@gmail.com), [alexfreetibet@gmail.com](mailto:alexfreetibet@gmail.com), [maxmek@mail.ru](mailto:maxmek@mail.ru)

**Abstract.** The use of multiphase power supply of a group of Peltier elements (PE) is considered to reduce the load on the power source. Schemes and a control layout with the use of the H-bridge, allowing the invert of the current through the PE, are given. The analysis of the operation of the used H-bridges and PE in the frequency range of the control PWM signal from 30 Hz to 32 kHz is performed. The algorithm for monitoring the current sensors is presented and the time diagrams of the currents are represented through the PE and H-bridges using a two-phase and four-phase control PWM signal for one, two and four phases of the supply. The results showed stable heating and cooling of the PE at frequencies from 30 Hz to 1 kHz. The use of multiphase power supply of PE made it possible to significantly reduce the load on the power source.

## 1. Introduction

An active study of the properties of Peltier thermoelectric elements (PE), for example, cooling systems on a crystal [1], as well as semiconductor lasers [2, 3], optical systems [4] and microwave devices [5], makes their application relevant for the development of new systems for cooling of precision electronic equipment. Such cooling systems, in comparison with air cooling, have high characteristics, for example, cooling capacity increased by 73.54% and energy consumption reduced by 42.20% [6, 7]. In modern processors, a high short-term load on the computational core contributes to rapid heating, which is hard for reaction of traditional air cooling systems. Instantaneous response of the cooling system to a sharp increase in the temperature of the processor can be obtained using cooling systems based on PE [6, 7]. However, such systems exert a high load on a power source, and when several PEs are used with a current consumption of more than 10 A, they increase the mass and dimensions of the power unit, which makes the widespread use of such cooling systems unreasonable. Thus, new approaches to the design of such systems are needed, allowing one to reduce the consumption current from the source of power when using a cooling system with several PE [8, 9]. One of the possible solutions to this problem is the use of multiphase power supply for PE. Such power supply, for example used for powering the processor, allows one to optimally distribute the currents by drivers, switches and power filters of a processor.

The aim of this paper is to investigate the possibility of using multiphase power supplies for a group of PE and to develop a multiphase power supply device with the ability to invert currents.



## 2. Hardware part

A multiphase power supply device is designed (Figure 1 (a)), which contains a microcontroller (MC) and an inverter on the control board, H-bridges (HB1, HB2), current probe (CP1-CP3), an analog-digital converter (ADC) and Peltier elements (PE1, PE2). Multiphase voltage supply is supplied to the PE, via H-bridges controlled by time-separated PWM signals from the MC (ATmega2560) [10]. The H-bridge is developed, the distinctive feature of which is that the active AE5 (IRFZ46) and CE3 control (BC547) elements allow one to control the H-bridge using a single PWM signal (Figure 1 (b)). The elements CE1 and CE2 control transistors AE1-AE4, which change the direction of the current through the PE. The use of transistors of different conductivity AE1, AE4 (IRF9540) and AE2, AE3 (IRFZ46) eliminates the possibility of a short circuit in the H-bridge circuit, since at high and low voltage levels on elements CE1 and CE2 is eliminated by using an inverter (HEF4049), which is also designed to change the direction of current flow through the PE depending on the operating mode (heating or cooling). Current measurement is carried out by three current probe (CP) signals from which they are digitized by the ADC and transmitted to the PC. Sensors CP1 and CP2 measure the currents flowing through PE1 and PE2, and the CP3 sensor measures the total current consumed by two H-bridges and PE. The CP transmit the measurement results to the ADC of the MC. The measurement time of the CP ACS712-20B is 5  $\mu$ s [11], the measurement error is  $\pm 1.5\%$ .

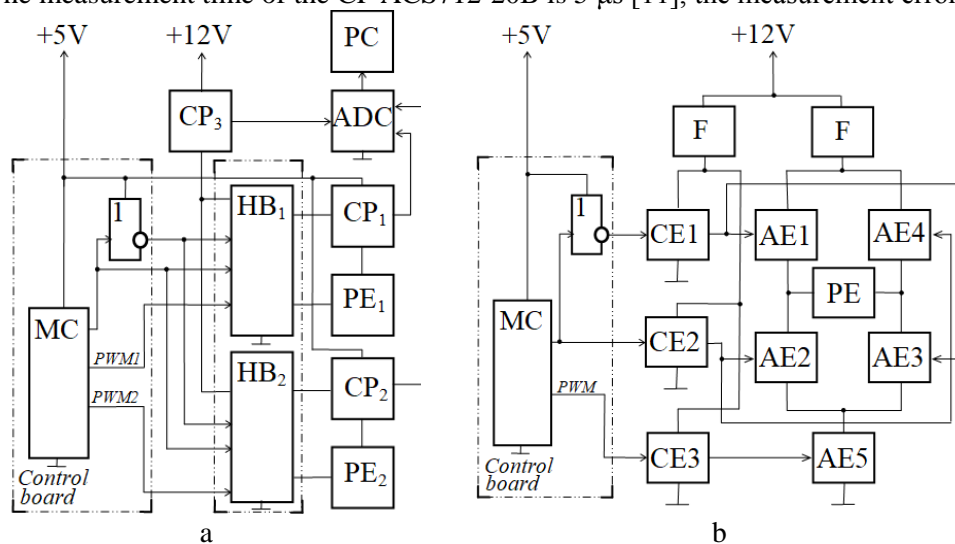
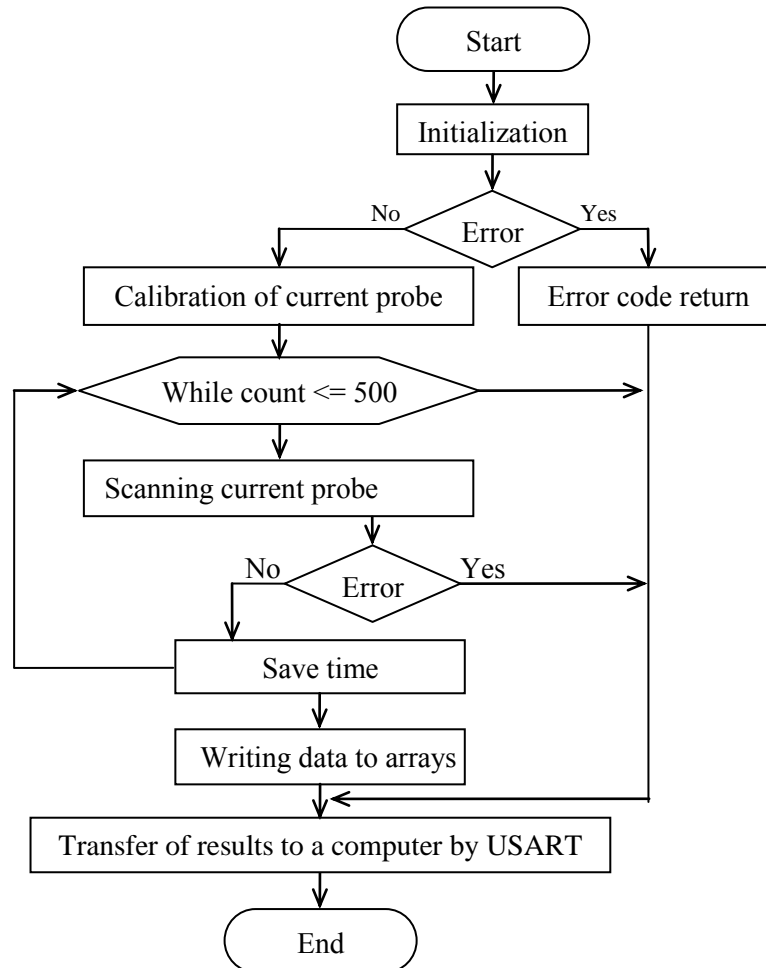

**Figure 1.** Schemes of devices: a – thermal control, b – H-bridge.

## 3. Software part

Reducing the load on the power supply from two or more H-bridges with PE is possible in the multiphase control mode of the PE group by means of PWM signals. To check and measure the currents on the PE, the two-phase, and then the four-phase operation of the power supply of the PE is selected. A program has been developed in the C language in the development environment of WinAVR for the ATmega2560. A multiphase is achieved by setting the initial counter value of a subsequent timer equal to one period. This allows one PWM signal to be time-resolved relative to the other, excluding the possibility of simultaneous operation of several PWM signals. The hardware timers (*Timer1* and *Timer3*) are configured in the "Fast PWM" mode with *TOP* (upper bound of the counter) equal to 0x1FF. The flowchart of the monitoring algorithm for CP is shown in Figure 2. Measurements of the H-bridge and PE currents occur in 3 stages: initialization, interrogation of CP, transfer of measured values to the PC. The initialization process consists of setting the MC timers and declaring objects: an instance of the CP class; four arrays for storing the result of the sensor interrogation and time; calibration of CP according to the method of [11]. The results of successive interrogation of the CP and the call to the times function are written on the arrays declared during the

initialization phase. If an error occurs while reading data from one of the CP, the program stops working and the error code is transmitted to the PC. Transmission of data stored in four arrays (three arrays are for the measurement results from CPs and one array is for time data) is carried out through the serial USART interface.



**Figure 2.** A block diagram of the sensor monitoring algorithm

Controlling the PE by means of PWM signals is performed using different frequencies calculated by the formula:

$$f_{OCn \times PWM} = \frac{f_{clk}}{N(1 + TOP)} \quad (1)$$

where  $f_{clk}$  is the clock frequency of the MC;  $N$  is the PWM signal pre-multiplier ratio taking values 1, 8, 64, 256, 1024,  $TOP$  is the maximum value upon which the counter timer is reset.

#### 4. Measurement

A prototype of the multiphase power supply device for PE has been developed (Figure 3). The current pulses of the PE and H-bridges are measured in the following modes of operation: control of two PEs without a shift and partial phase shift, control of one PE and control of two PEs with a complete phase shift. The control signal is a PWM signal of frequency  $f = 242.7$  Hz, duty cycle  $D = 40\%$ , pulse width  $W_+ = 1.62$  ms and time between pulses  $W_- = 2.51$  ms. Figure 4 (a) shows the pulses of the PE currents and the total current of the H-bridges in the operating mode of two PEs without a phase shift.

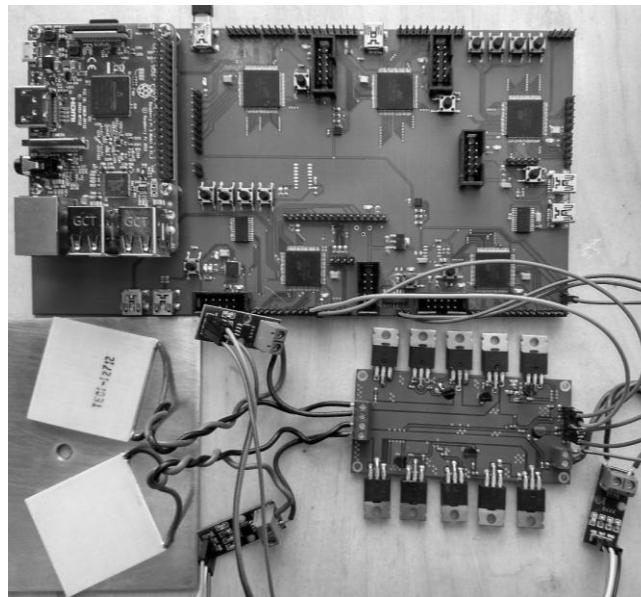

**Figure 3.** A prototype of a multiphase power supply device with two PEs.

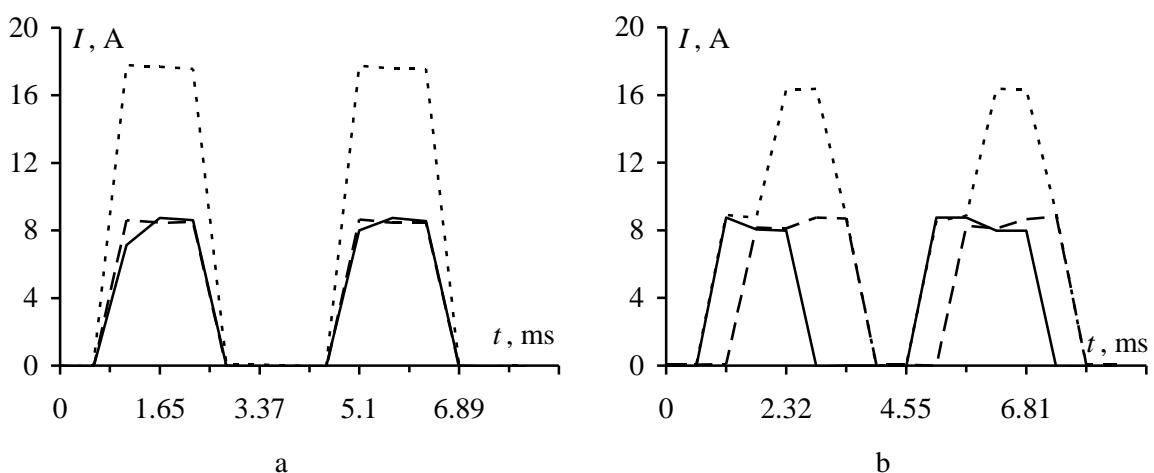

**Figure 4.** Amplitude of current pulses flowing through PE1 (-), PE2 (- -), and total supply current of H-bridges (- - -) in operating modes: a – without phase shift, b – phase shift 45°.

The pulse currents of each PE achieve values of  $I_1=I_2=8.65$  A. The total current consumed by the H-bridges with two PEs reaches  $I_3=17.74$  A (a power supply unit with a maximum output current of 17.74 A was used). The difference in currents of 440 mA is divided into 220 mA for each H-bridge and dissipated as heat on the radiators.

When the two control signals are separated in time by 0.9 ms, the total current consumption of H-bridges with PE reaches the value of  $I_3=16.36$  A (Figure 4 (b)). At the same time, the current pulse levels of the PE reach values  $I_1=I_2=8.75$  A, but only at the times of operation of one PE. During operation of two PEs, currents  $I_1$  and  $I_2$  are reduced to the value of 8 A. In the mode of operation of one PE, the current of the PE reaches 9.6 A (Figure 5 (a)), while the measured total current during operation of two PEs without a shift of the control signal can reach 20 A.

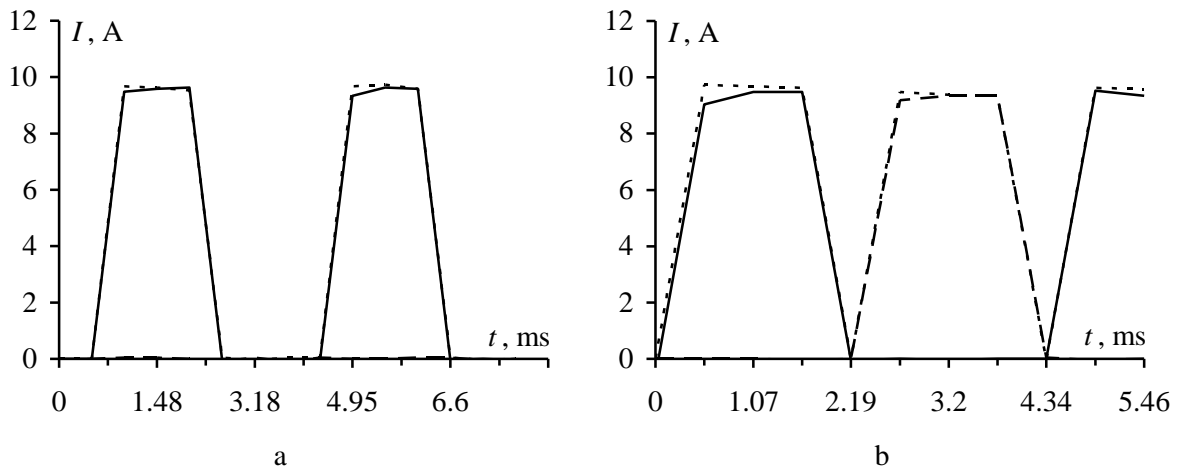

**Figure 5.** Current pulses at  $D=40\%$  on PE1 (-), PE2 (- -) and total supply current of H-bridges (- - -) in the operating modes: a - one PE, b - with a phase shift of  $90^\circ$ .

When the control signals are separated in time by 2 ms, a full ( $90^\circ$ ) phase shift of the power supply for one of the PEs is provided (Figure 5 (b)). Thus, it is possible to reduce the total consumed current from the power source to  $I_3=9.7$  A and to increase the currents flowing through the PE to levels  $I_1 = I_2=9.55$  A. Also, multiphase power is implemented for four PEs with control of PWM signals and a phase shift of  $90^\circ$ . The total current consumption of H-bridges with PE ( $I_3$ ) did not exceed 10.12 A (Figure 6).

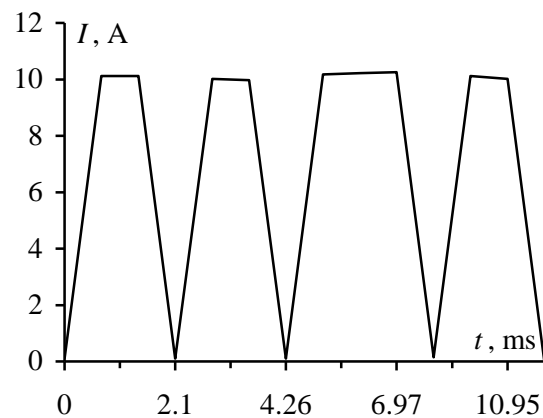

**Figure 6.** Total power supply current of the H-bridges at  $D=20\%$  in the four-phase mode of the PE group.

The control signal frequency for four-phase power supply is 121.2 Hz (depending on the number of phases and coefficient  $N$ ) with  $D=20\%$ ,  $W_+=1.62$  ms and with time shifts relative to first pulse  $W_- = 6.63$  ms, 2.06 ms, 4.13 ms, and 6.18 ms, respectively.

## 5. Conclusion

The possibility of using a multiphase power supply for a group of PEs is shown, which allows one to reduce the load on the power supply up to four times when operating in a four-phase mode. The schemes and the device of multiphase power supply of PE are presented. The H-bridge is developed, controlled by a single PWM signal and also allows inverting the current through the PE in the frequency range of the control signal from 30 Hz to 1 kHz. An algorithm for monitoring the CP

current is presented and time diagrams of the currents through the PE and H-bridges are presented using a two-phase and four-phase control PWM signal for one, two and four phases of supply. The results showed stable heating and cooling of PE at frequencies from 30 Hz to 1 kHz.

## 6. Acknowledgments

This research was supported by the Ministry of Education and Science of the Russian Federation (RFMEFI57417X0172).

## 7. References

- [1] Kim S, Lee H, Kim N, Yoo J 2010 A thin film thermoelectric cooler for chip-on-board assembly *The Institute of Electronics, Information and Communication Engineers (IEICE)* **7(21)** 1615–21
- [2] Zou W -D, Ye Q, Xie H -H, Zhao L -Z 2008 LD temperature control based on TMS320F2812 *Infrared and Laser Engineering* **37(4)** 642–6
- [3] Xie H, Zou W, Huang C, Wei Y 2009 LD temperature control system based on ШИМ comparison amplifier *Chinese Journal of Scientific Instrument* **30(7)** 1530–4
- [4] Dubrovin A N, Mandel' A E, Shandarov S M, Shmakov S S 2011 A thermostatic controller for investigating temperature dependencies of optical effects in crystals *Instruments and Experimental Techniques* **54(4)** 593–5
- [5] Zhou F, Wang R -G, Ji Z -B, Zhao L 2014 Tunable photonic microwave signal generation based on TEC temperature controller **25(9)** 1691–4
- [6] Sun X, Zhang L, Liao S 2017 Performance of a thermoelectric cooling system integrated with a gravity-assisted heat pipe for cooling electronics *Applied Thermal Engineering* **116** 433–4
- [7] Sun X, Yang Y, Zhang H, Si H, Huang L, Liao S, Gu X 2017 Experimental Research of a Thermoelectric Cooling System Integrated with Gravity Assistant Heat Pipe for Cooling Electronic Devices *Energy Procedia* **105** 4909–14
- [8] Osintsev A, Sobko A, Komnatnov M 2016 Temperature Controller for External Surface of Waveguide Int. Siberian Conf. on Control and Communic. (SIBCON 2016) 1–4
- [9] Osintsev A, Sobko A, Komnatnov M 2016 *Software under control of a real-time operating system for environmental shielded TEM-chamber* 17th Int. Conf. of Young Specialists on Micro/Nanotechn. and Electron Devices 159–63
- [10] microchip.com 2018 Available: [http://ww1.microchip.com/downloads/en/DeviceDoc/Atmel-2549-8-bit-AVR-Microcontroller-ATmega640-1280-1281-2560-2561\\_datasheet.pdf](http://ww1.microchip.com/downloads/en/DeviceDoc/Atmel-2549-8-bit-AVR-Microcontroller-ATmega640-1280-1281-2560-2561_datasheet.pdf)
- [11] www.allegromicro.com 2018 Available: <https://www.allegromicro.com/~media/Files/Datasheets/ACS712-Datasheet.ashx>